

SETUP INSTRUCTIONS

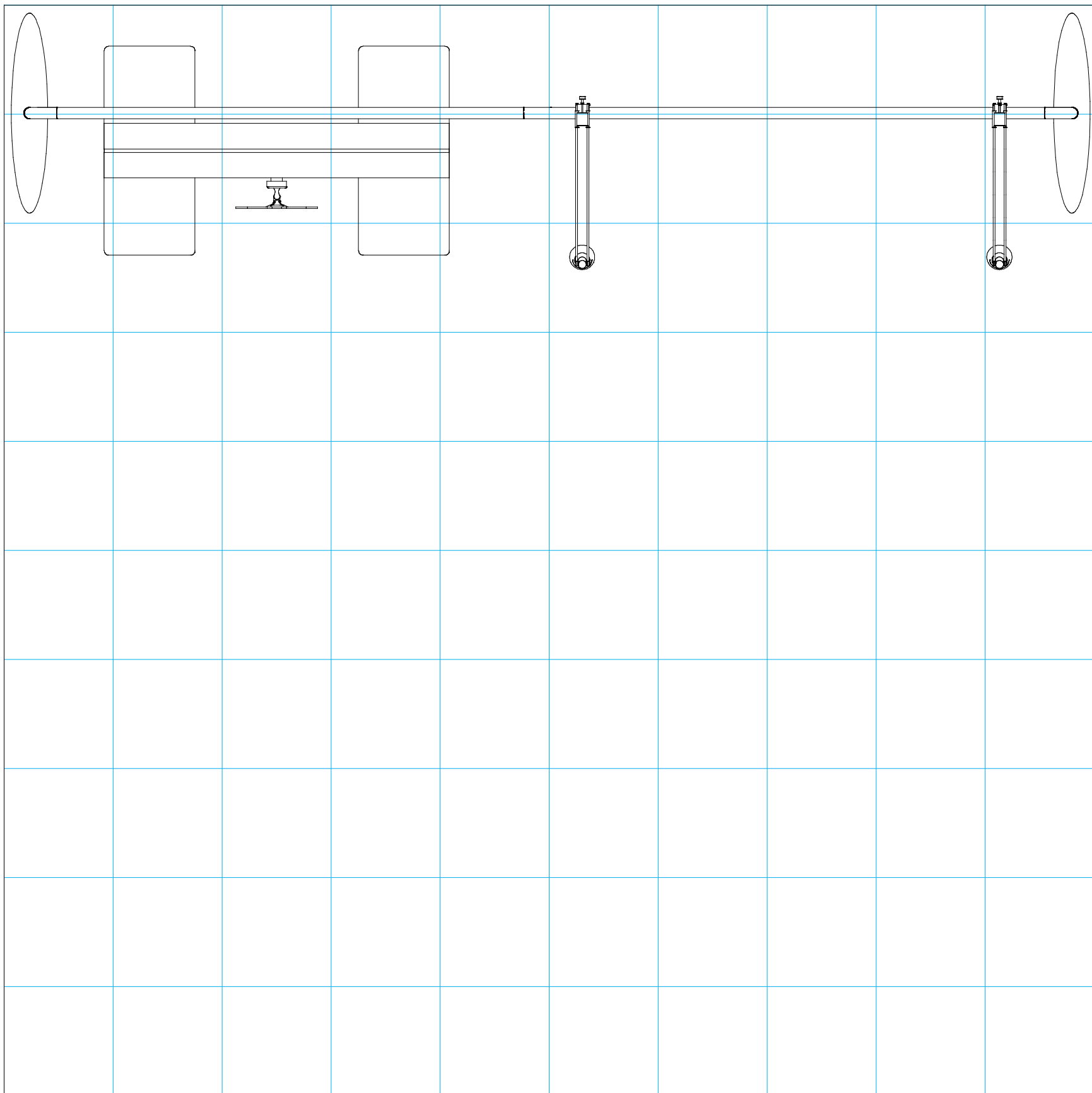

= 1 sq foot

General Setup Instructions

- Read entire setup instruction manual prior to unpacking parts and pieces.
- The setup instructions are created specifically for this configuration.
- Setup instructions are laid out sequentially in steps, including exploded views with detailed explanation for assembly.

Cleaning & Packing

- For Cleaning Metal, Plex, & Laminate Parts: Use a **MILD NON-ABRASIVE** cleanser and soft cloth/paper towel to clean all surfaces.
- Keep exhibit components away from heat and prolonged sun exposure.
Heat and UV exposure will warp and fade components.
- Retain all provided Packing Materials. All provided packing materials are for ease of repacking & component protection.

Disassembly

- For loss prevention, tighten all set screws and locks during disassembly.

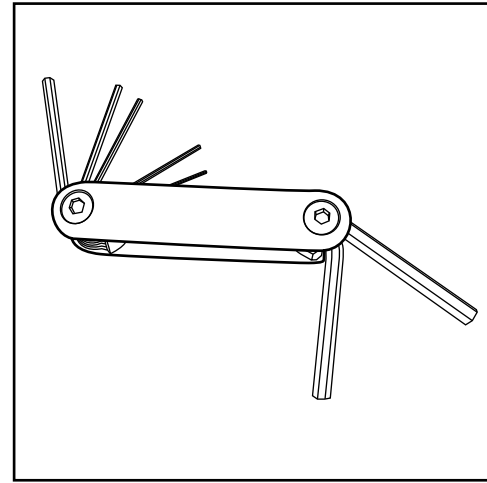

Hex Tool - Essential for Assembly

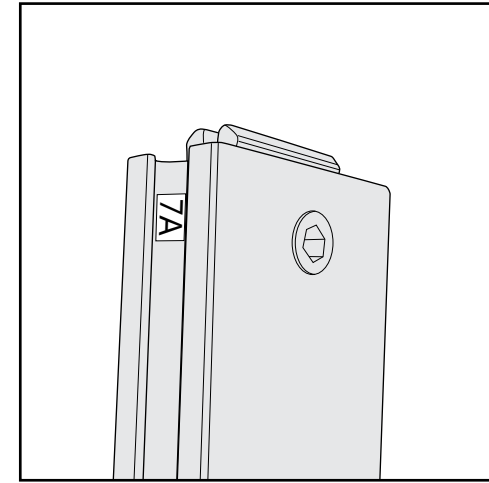

Part Identification - Numbering

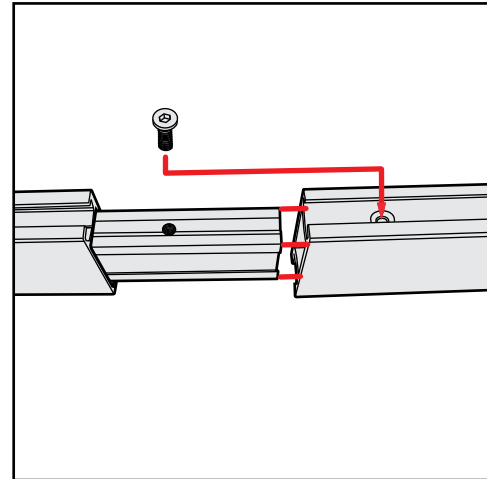

Spline Connection

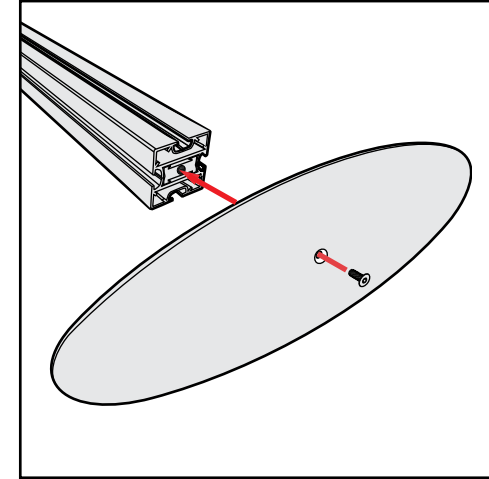

Base Plate & Extrusion Connection

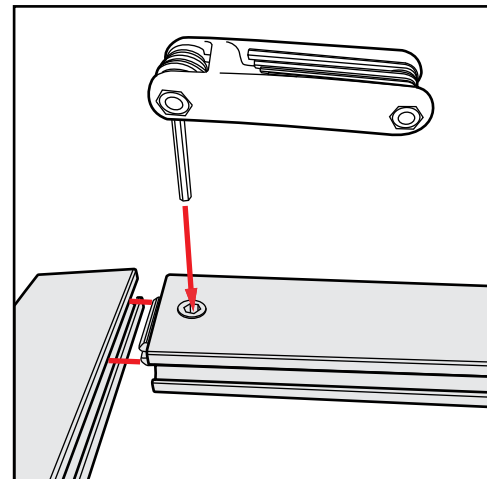

Extrusion & Lock Connection

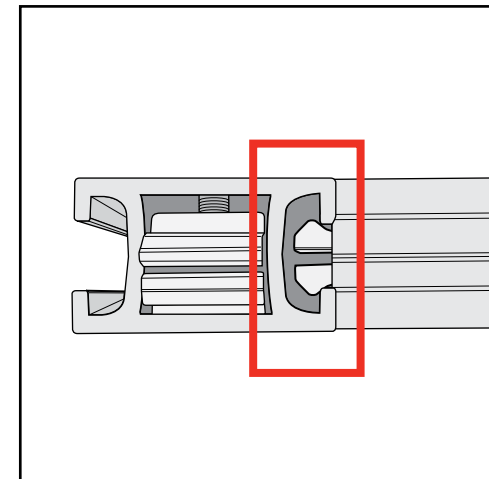

Engaged Lock



WARNING



DO NOT USE POWER TOOLS



LADDERS OR LIFTS
MAY BE REQUIRED



ALL CONNECTIONS MUST
BE TIGHTLY SECURED

Straight Connection

When assembling frame, first attach all **straight connectors**, then attach **corner connectors**.

- 1) Place extrusions end-to-end.
- 2) Loosen all knobs, then slide **straight connectors** across the seam of extrusions.
- 3) Tighten all knobs to secure connection.

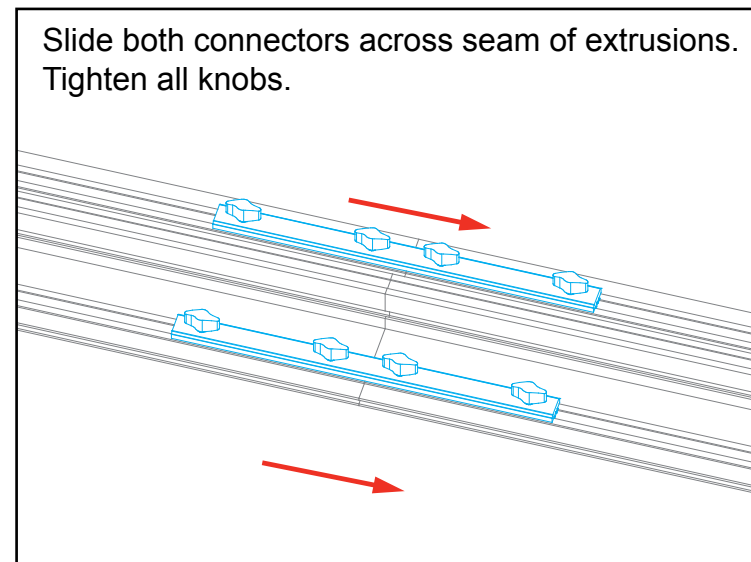
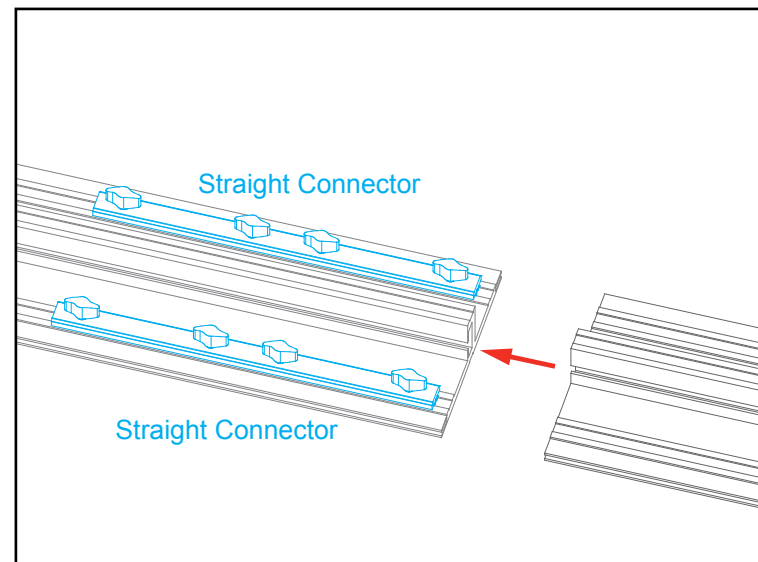

All knobs must be tightened securely to ensure a proper connection.

Disassembly

- 1) Loosen all knobs.
- 2) Slide connectors off of one extrusion.
- 3) Tighten knobs to prevent loss during packing & shipping.

Keep straight connectors in groove of extrusion. Do not remove connectors during disassembly.

Corner Connection

- 1) Loosen knobs, then slide vertical extrusions onto **corner connectors** of **lower** horizontal extrusion.
- 2) Slide **corner connectors** of **upper** horizontal extrusion into grooves of vertical extrusions.
- 3) Tighten all knobs to secure connection.

Disassembly

- 1) Loosen knobs on vertical extrusions.
- 2) Slide the vertical extrusions off of **corner connectors** on lower and upper horizontal extrusions.

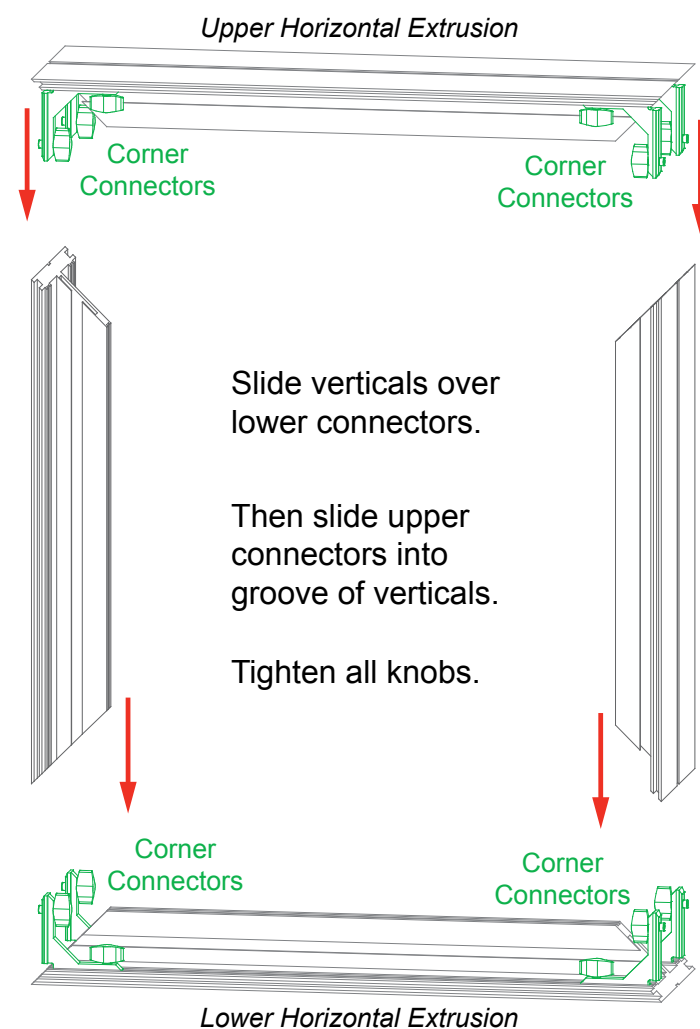

Adjust connectors if necessary to prevent gaps in connection.

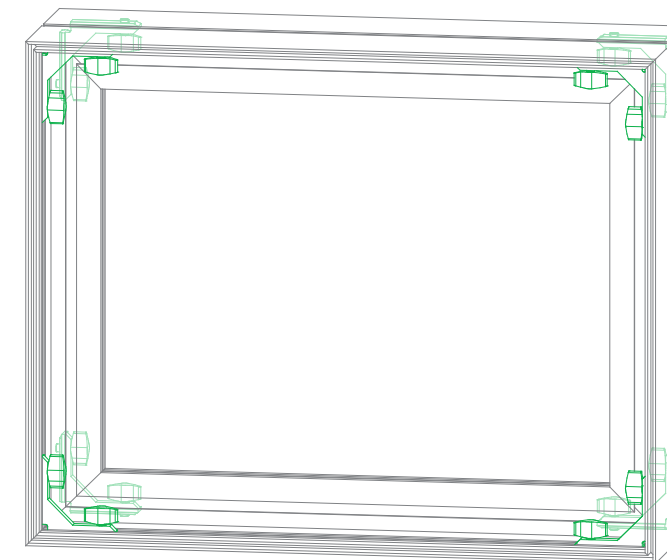

COMPLETED ASSEMBLY

All knobs must be tightened securely to ensure a proper connection.

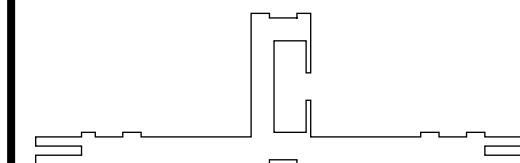

CEI152 Profile

SEG Graphic Installation *in 3 Steps*

STEP 1: Attach Corners

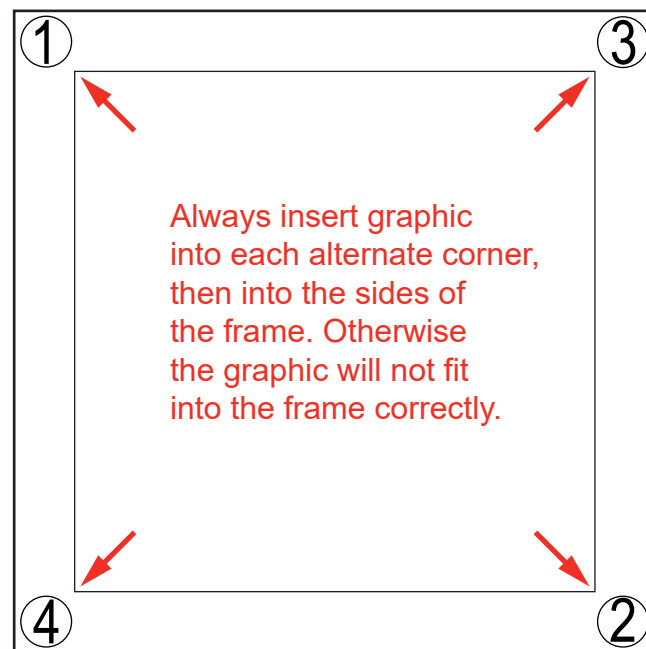

STEP 2: Attach Middle

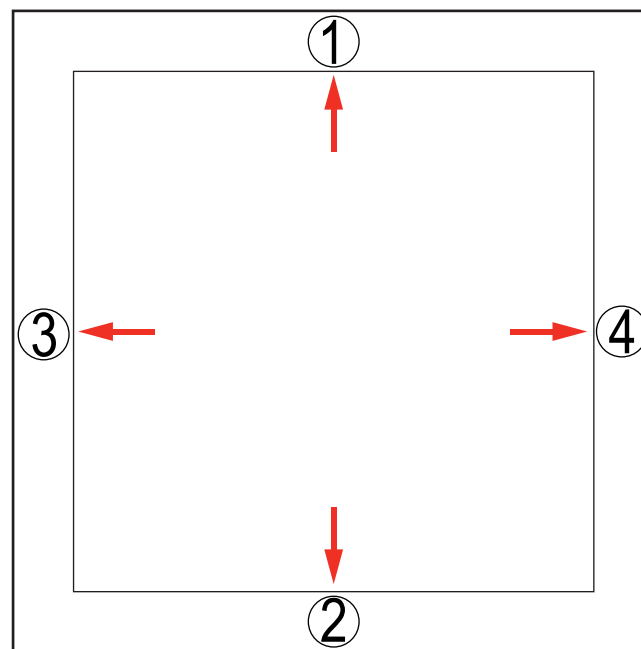

STEP 3: Attach Sides

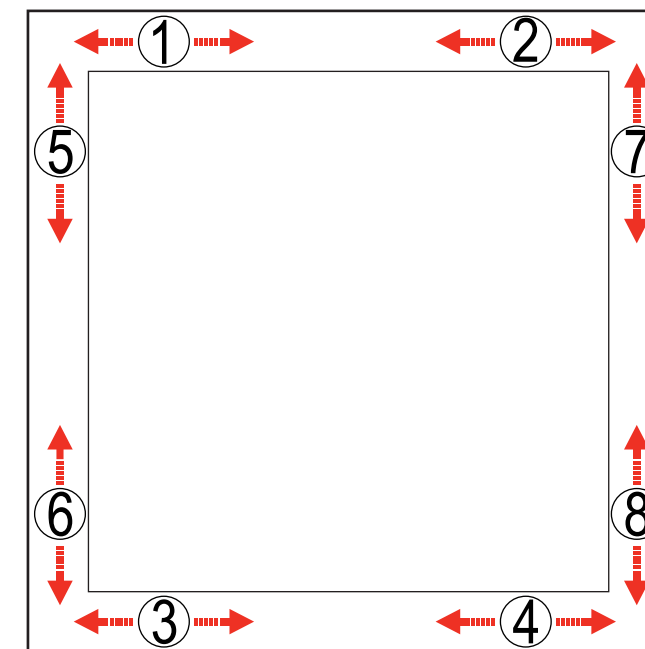

Insert narrow side of silicone welt into the channel at corner 1, with fabric to the outside.

Repeat for opposite corner 2, then corner 3, then corner 4.

Once corners are attached, press the middle of edge 1 into the channel. Then press middle of edge 2 into the channel on opposite side.

Repeat with edge 3 & 4.

Once the middle of sides are attached, fully press the silicone welt into the channel, between center and corner at location 1. Repeat the process between center and corner at location 2.

Do the same for welt on opposite side, at locations 3 & 4. Then repeat for locations 5 & 6 and 7 & 8.

Once the welt is fully inserted on all sides, smooth out edges as needed for a perfect fit.



To remove the graphic from the frame, locate the fabric **pull tab**. Gently pull on the tab to remove the graphic.

Install video:



Top View of Each Level

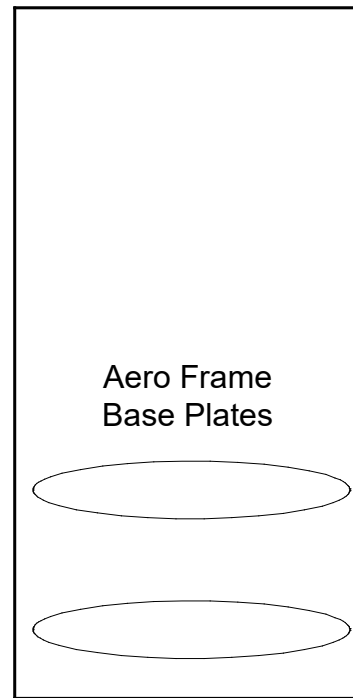

Level 1
(Bottom level)

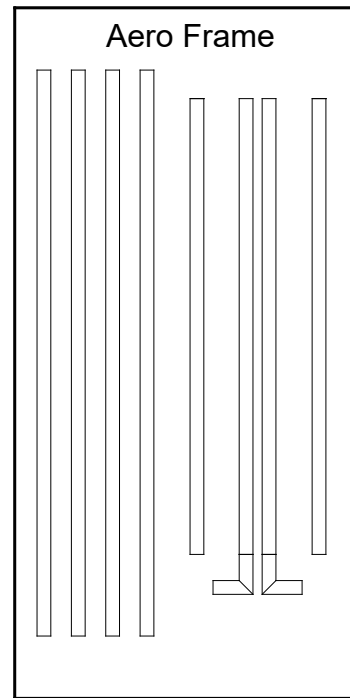

Level 2

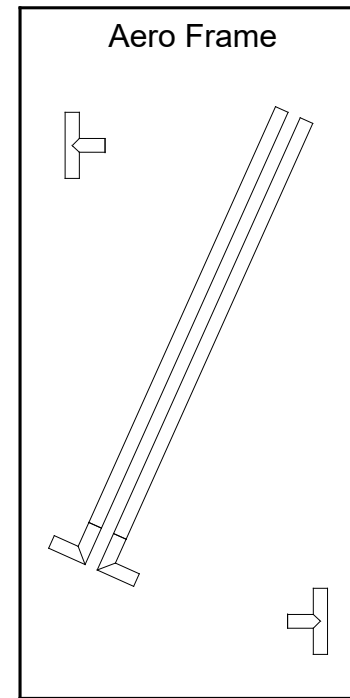

Level 3

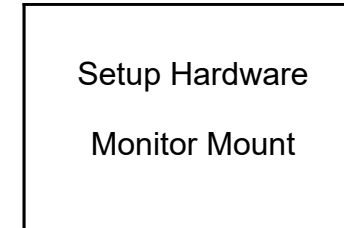
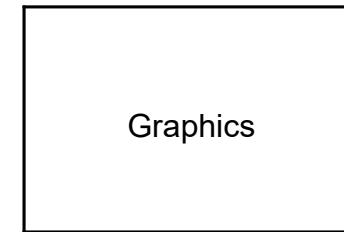
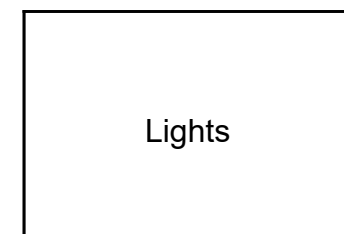

Top View of Each Level

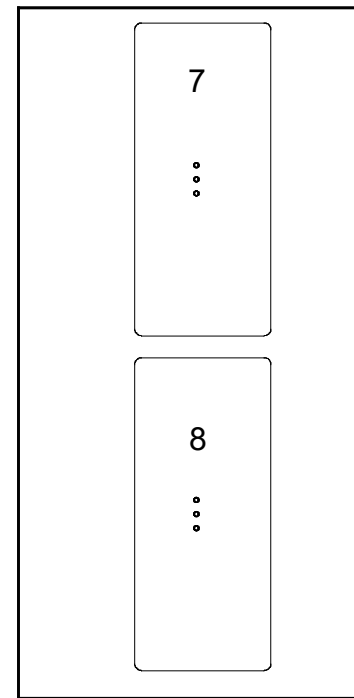

Level 1
(Bottom level)

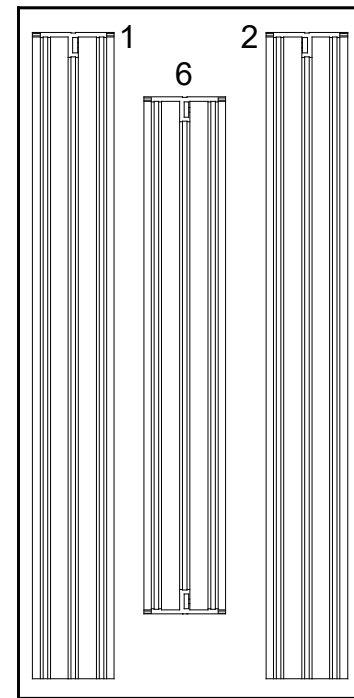

Level 2

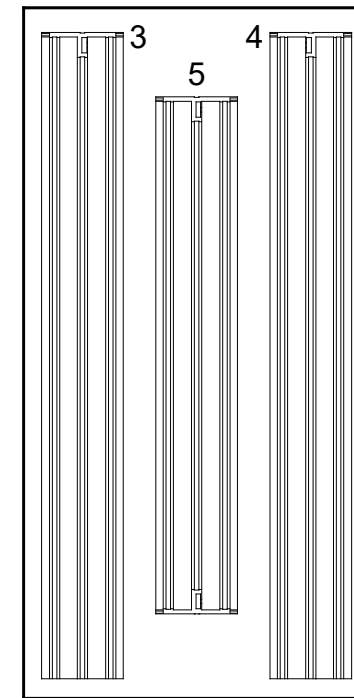

Level 3

AERO

Using Your Setup Instructions

The Aero Setup Instructions are created specifically for your configuration. The instructions include an exploded view of the frame which is sequentially labeled. We encourage you to review the instructions before attempting to assemble your exhibit.

Connections are kept very simple; no tools required. Everything assembles with push-button connectors.

Cleaning and Packing Your Display

- 1) Use care when cleaning aluminum extrusion or acrylic inserts. Use only non-abrasive cleaners.
- 2) Retain all packing material. It will make re-packing much easier and will reduce the likelihood of shipping damage.

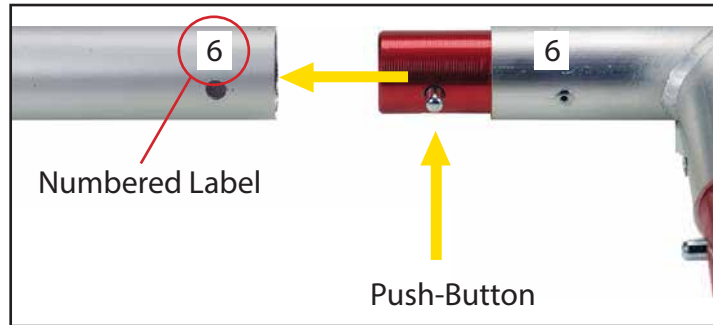

Connections are made by holding the button down and sliding the red tube into opposing tube until button locks into the hole of the opposing tube. To disassemble, push button and pull or twist extrusions apart.

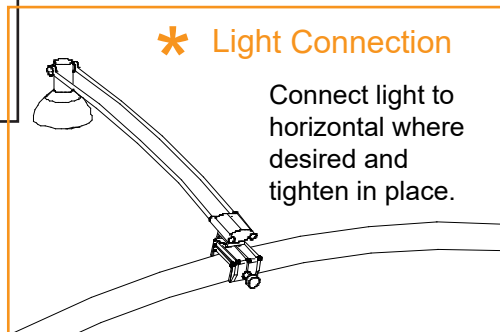
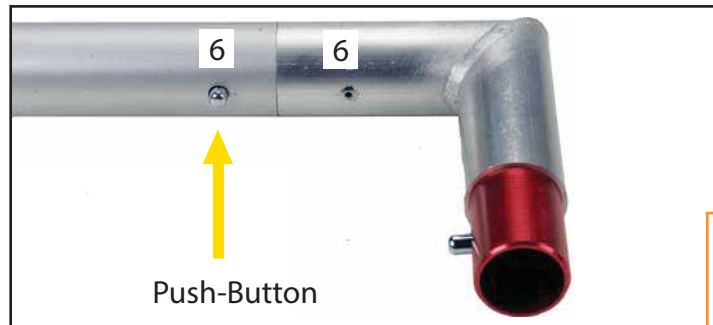

Steps:

- 1) Assemble frame together in numerical order.
- 2) Apply pillowcase graphic over assembled frame, then zip closed.
- 3) Clamp lights to top of assembled frame.

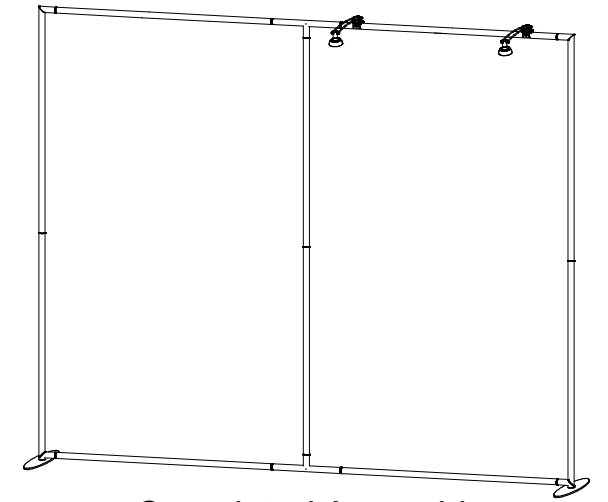

Completed Assembly

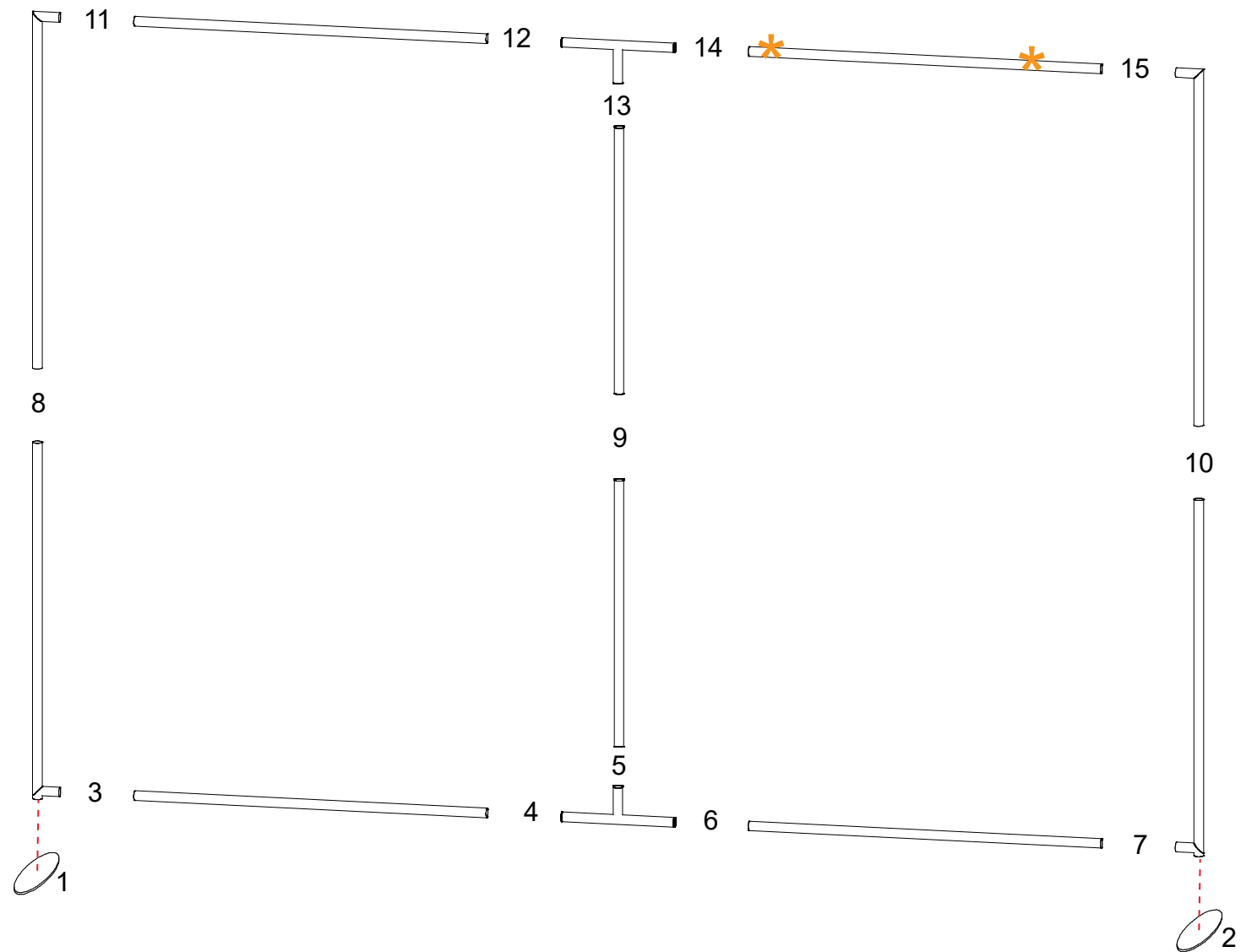

Item	Qty.	Description
1	1	47.5”h CEI152 Vertical Extrusion
2	1	47.5”h CEI152 Vertical Extrusion
3	1	47.5”h CEI152 Vertical Extrusion
4	1	47.5”h CEI152 Vertical Extrusion
5	1	38”w CEI152 Horizontal Extrusion
6	1	38”w CEI152 Horizontal Extrusion
7	1	23” x 10” SF-23 Base Plate
8	1	23” x 10” SF-23 Base Plate

Assemble frame flat on ground.

Steps:

Refer to the CEI152 Frame Assembly general information page.

- 1) Assemble verticals [1-2], [3-4] using straight connectors.
- 2) Connect verticals [1/2], [3/4] between horizontals [5,6] using corner connectors.
- 3) Attach U-Channel to horizontal [5]. See [U-Channel Attachment](#) detail.
- 4) Connect Base Plates [7,8] to lower horizontal, using bolts & wing nuts.
- 5) Connect power cords to Supernova lights as shown.

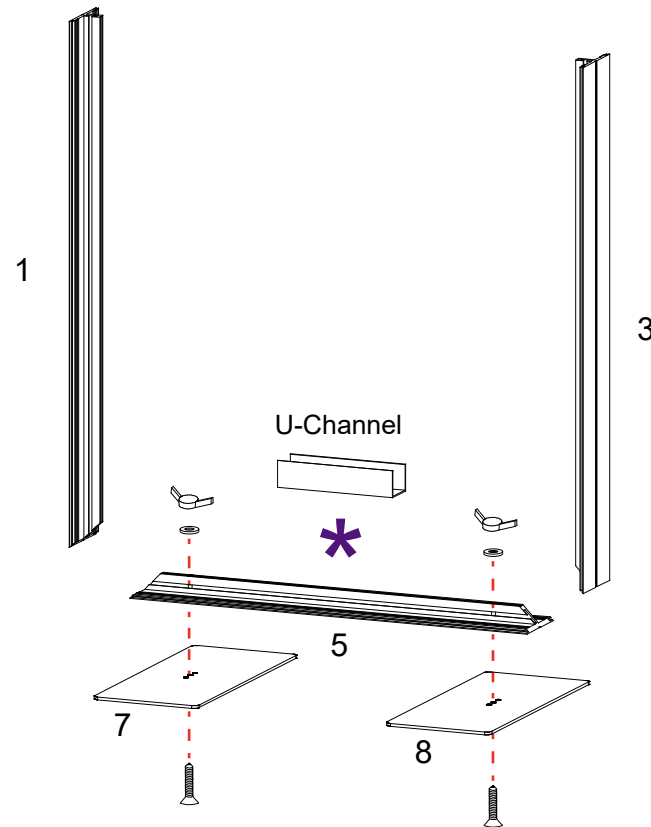
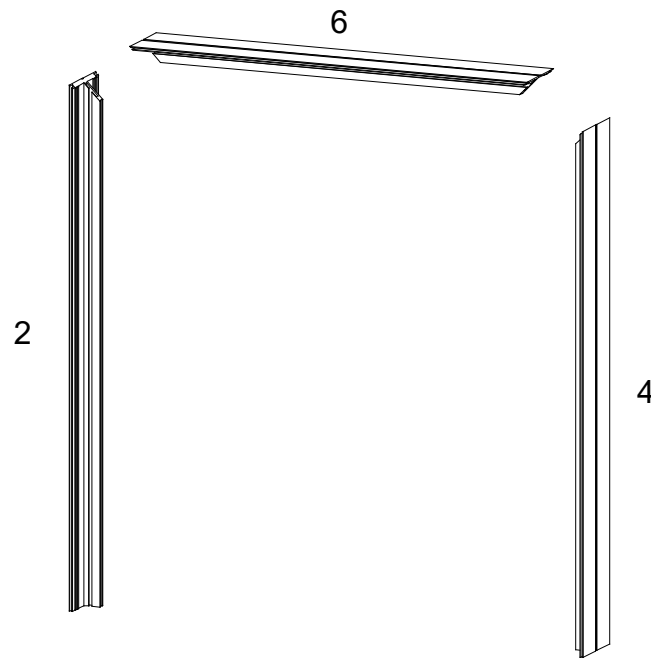

FRONT VIEW

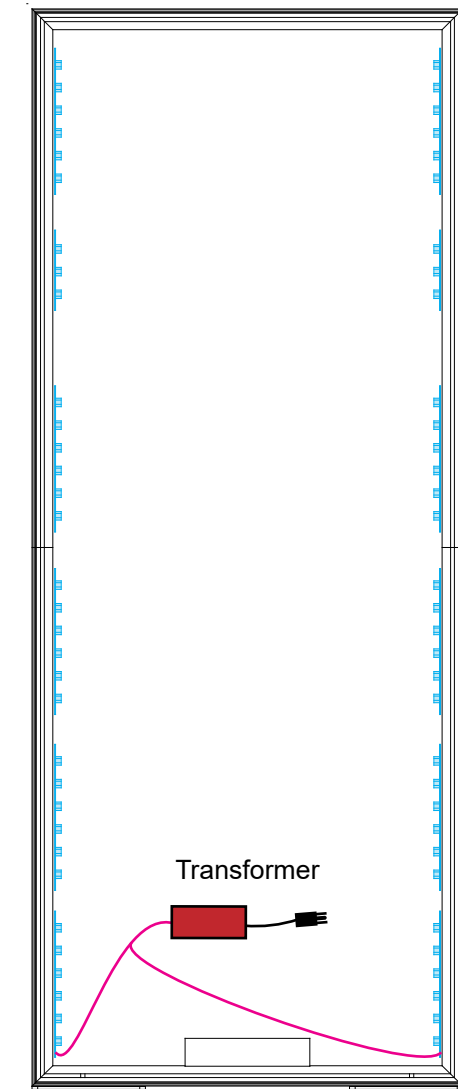

FRONT ELEVATION VIEW

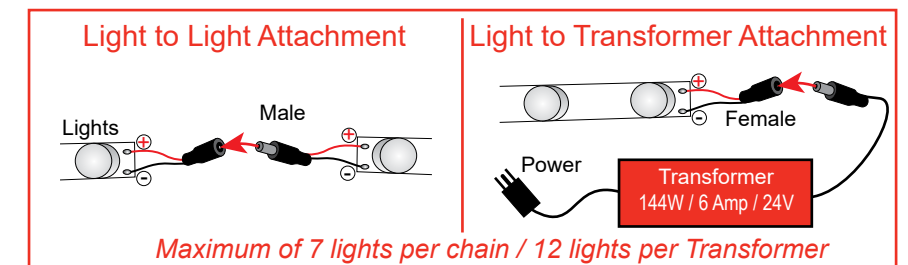
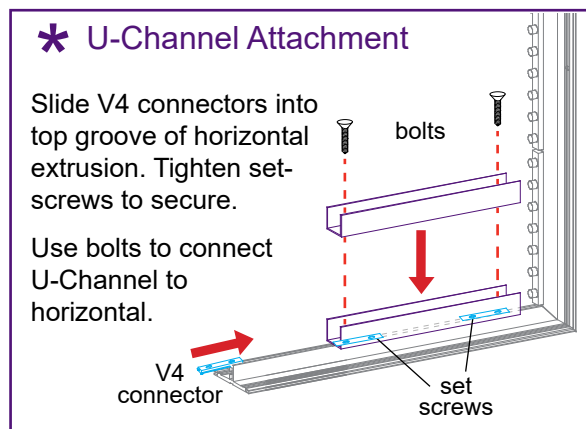

Steps:

- 1) Apply SEG graphic to front of lightbox assembly.
- 2) Apply SEG blocker to back of lightbox assembly.
- 3) Place lightbox in front of backwall as shown on layout page.

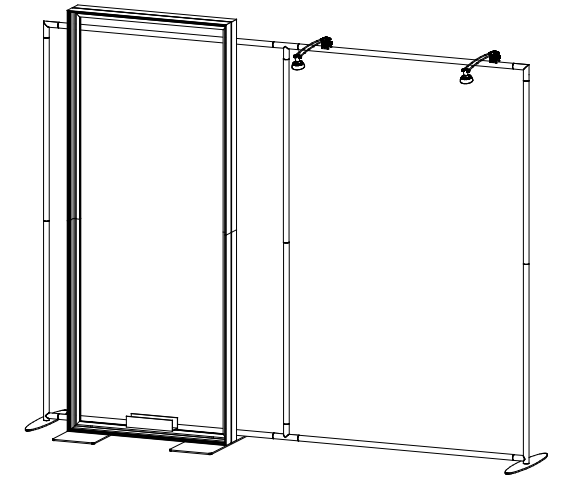

Completed Assembly

SEG Graphic Installation in 3 Steps

The Perfect Fit

STEP 1: Attach Corners

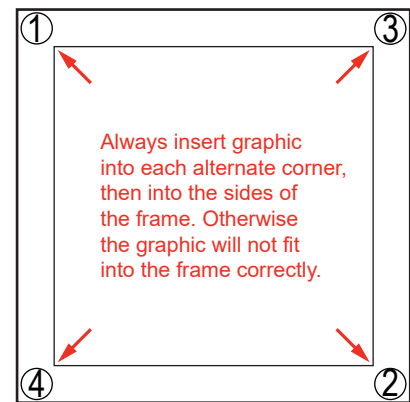

Insert narrow side of silicone welt into the channel at corner 1, with fabric to the outside.

Repeat for opposite corner 2, then corner 3, then corner 4.



STEP 2: Attach Middle

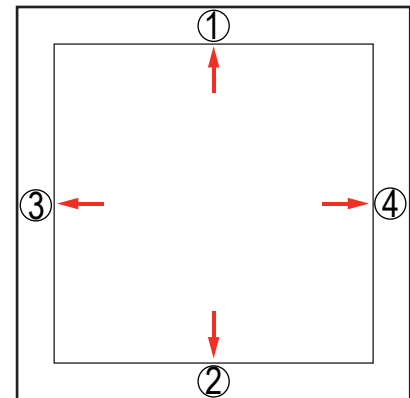

Once corners are attached, press the middle of edge 1 into the channel. Then press middle of edge 2 into the channel on opposite side.

Repeat with edge 3 & 4.

STEP 3: Attach Sides

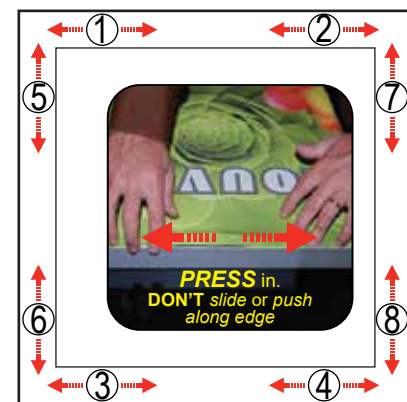

Once the middle of sides are attached, fully press the silicone welt into the channel, between center and corner at location 1. Repeat the process between center and corner at location 2.

Do the same for welt on opposite side, at locations 3 & 4. Then repeat for locations 5 & 6 and 7 & 8.



To remove graphic from the frame, locate the fabric pull tab. Gently pull on the tab to remove the graphic.

